



Warszawa

Control Unit

type

MD-2

MD-2.A

MD-4

MD-4.A

series **U3**

**USER'S
MANUAL**

edition 2U3en

Read carefully this entire manual BEFORE installation.

The installation can be started after the content of this manual has been fully understood.



Follow the recommendations and warnings provided in this manual to maintain safety when installing and operating the unit.



Keep the manual as reference for the User of the Two-Threshold Gas Detection System.

1.	Application and compatibility table	page 2
2.	Specifications	3
3.	Description and connection of MD in the system	4
4.	Installation of MD	7
	PROBLEM? Helpful tips	10
5.	Maintenance / operation	10
	Periodical Inspection Protocol	12

PRODUCER:

PRODUCER: **GAZEX**
gazex Baletowa 16, PL 02-867 Warsaw, POLAND
 Tel: +48 22 644 2511 Fax: +48 22 641 2311
 gazex@gazex.pl www.gazex.com

©gazex '2011 All right reserved. Reproducing and copying of this manual in whole or part without consent of GAZEX is prohibited. Logo of gazex, name of gazex, dex, ASBIG, Active Safety System of Gas System are reserved trademarks of GAZEX. Logo of TÜV CERT EN ISO 9001 is a reserved trademark of TÜV Rheinland Euroqua.

Work and live SAFER with us!!!

©gazex

1. APPLICATION

Control units, types **MD-2, MD-2.A, MD-4, MD-4.A** of U series are intended **ONLY** for control of and supplying power to gas detectors of **DEX®** type - F and FA series and **DG type** - F1 and FvU series, manufactured by GAZEX for use in Two-Threshold Gas Detection System.

Each of the mentioned units is referred to hereinafter as „**MD**” module (or control unit) unless the description refers to other specific model.

Terms: „Detector” or „DEX” used hereinafter shall refer to DEX/F... and DG detectors for all gas types unless the description shall refer to other specific model.

NOTE:

Operation of MD-series control units with DEX® detectors of C series, versions M... and DG series M... is allowed provided that the maximum permitted lengths of connection cables between the detector and the module (described in Section 4.2 of this manual) are reduced by 50%.

The unit can control operation of one or two (MD-2, MD-2.A) or up to four (MD-4, MD-4.A) two-threshold DEX and/or DG detectors (various detector types can be used at a time).

Features and functions of MD:

- ◆ - provides 9V voltage to individual detectors (including load control) – can operate with DEX/F... detectors
- ◆ - controls the cable connection with the detectors (provides signals in case of a break of any conductor),
- ◆ - provides optical signals and stores alarm states of each detector and state of control outputs,
- ◆ - allows manual release of output command signals (without a need to generate alarm signals of detectors),
- ◆ - allows continuous 12V DC power supply for additional devices („MDX” terminal)
- ◆ - allows operation with additional modules (cascade-wise) through alarm input (galvanically isolated)
- ◆ - 12V voltage alarm outputs supply power to additional acoustic and optical signalling devices
- ◆ - contact outputs (galvanically isolated from the system) control fans, motors, contactors and information boards
- ◆ - „EMERGENCY” contact output (galvanically isolated from the system) informs on emergency state of the module.

1.1. TABLE OF COMPATIBILITY

Type of Detector	Series/models	MD Control Unit series		
		U3, U2, U1, MCU, MC	MB,MA,M(7...9)	M(1...6), nx
DEX/F	(DEX-nn)	++	--	--
DEX/FA	(DEX-nE)	++	+	--
DEX/C	Cn (without DEX-2)	+	++	+
DEX series H	nHn, nx (without DEX-2)	+	++	+
DG v.F1	All models	++	+	+
DG series M	Mn	+	++	+
DG series H	nHn, nx (without DG-2)	+	++	+
DEX-2*, DG-2*	All series	--	--	+

* - without DEX-2.L and DG-2.L

Legend:

n = digit

x = any capital letter

++ = recommended cooperation (full functionality of the set)

+ = conditional cooperation (with limited functionality or installation parameters of the set)

-- = cooperation not allowed

NOTE:

In view of the continuous improvement of products and the desire to provide full and detailed information on those products and to offer knowledge necessary to properly operate the products for a number of years, on the basis of the previous experience of Customers, GAZEX reserves the right to introduce minor changes in specifications of the products delivered, not indicated in this Manual and to modify its content. Therefore, we ask you to verify and confirm with the Manufacturer that the version of the User's Manual in your possession is up-to-date (providing type and series of the device being operated and the number of the manual version indicated in the footer of the document).

2. SPECIFICATIONS

Supply voltage	MD-2, MD-4 - 230V AC, 50Hz (allowed voltage fluctuations: +10%,-14%) MD-2.A, MD-4.A - 12V DC (allowed: 10.5V ÷ 13.8V=)
Power consumption	max. 15W (MD-...A : max 12W)
Operating temperature	+5°C to 35°C recommended optimal, -10°C to +40°C allowed constantly, -15° C to 45°C allowed periodically (<2h/24h)
Number of measurement channels	2 , two-threshold detectors (MD-2...) 4 , two-threshold detectors (MD-4...)
Alarm thresholds	two : warning - ALARM 1 (A1) , alarm - ALARM 2 (A2)
Alarm memory	for each channel and each level - optical, joint acoustic, output signal memory of each level – optical (possibility to deactivate with W2 function switch „BEZ PAM.”)
Memory resetting	using button on front plate (accessible when cover lifted)
Signal interlock	inputs: approx. 60 s, after turning the power on; outputs: approx. 20 s (delay), possibility of permanent interlock (service mode) using W2 function switch „SERWIS”
Optical indication (for each detector and output)	A1 – red LED – 1st gas concentration threshold exceeded A2 - red LED – 2 nd gas concentration threshold exceeded
Acoustic indication	internal piezoceramic siren (intermittent signal = module requires servicing), volume: approx. 60dB/1m; possibility of shutting down (using W2 function button „CISZA”)
Supplying power to sensors	9V DC, short-circuit- and overcurrent-protected 200mA
Failure indication	yellow LED
Detector power on indicator	green LED (separate for each detector), overload indication
Quick release of output signals	manual, using „TEST” button under terminal strip cover, simultaneous for both thresholds
Unit powering control	green LED; indicates also heating state
Contact outputs	NC and NO for A1, A2 , voltage-free; current-carrying capacity: max. 4A (with resistance load) or max. 2A (with inductive load -motors) or max. 0.6A (with purely inductive load – fluorescent lamps); max. 250V AC or 24V DC; NO and NC for AWARIA (FAULT) , voltage-free, current-carrying capacity: max. 4A (with resistance load) or max. 2A (with inductive load); max. 30V AC or 24V DC
Voltage outputs	<ul style="list-style-type: none"> ■ 12V DC , not stabilized for A1 and A2 states, total load = max. 0.3A, for connection of SL..., S-3, LD... signalling devices ■ 12V DC continuous, not stabilized, for powering MDX module or other devices, max. load 0.2A
Alarm inputs	12V DC voltage inputs (5÷ 16V, max. 20mA) for A1, A2; instantaneous, galvanically isolated from other MD circuits; for cascade connection of modules or other devices
Overload protections	fuse of primary 230V AC or 12 V DC supply circuit, self-resetting fuses with shorting current limitation of NAP.12V outputs, electronic fuses with current limitation for each detector
Dimensions, weight	215 x 240 x 115 mm, (H x W x D in mounting positions); approx. 1.5kg
Housing	ABS, 6 cable glands, IP54 , 3-point mounting

Fig.2. Required mounting area

Template for hole drilling is located on cardboard box lid.

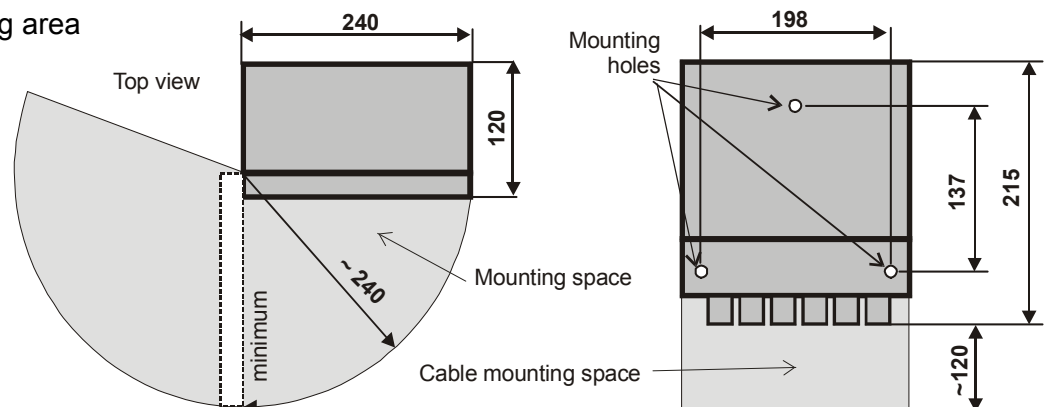

3. DESCRIPTION AND CONNECTION METHOD



Picture.3.1 MD front plate (mounting position)

- Input state control lamps (for individual detection lines)
- Output state control lamps
- Serial/version number
- Alarm memory resetting button
- Terminal compartment cover

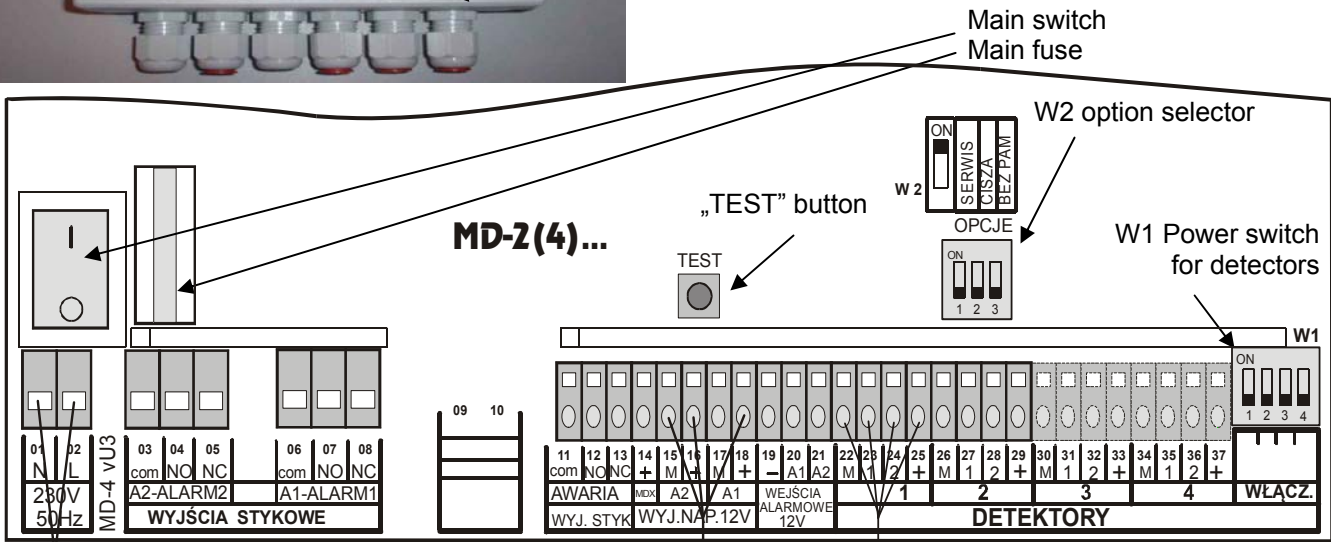

NOTE: terminals [M] of module earth are galvanically separated from earth of 12V ALARM INPUTS (terminal „_”, [19]) !

Fig. 3.2. Terminal chamber – electrical connections

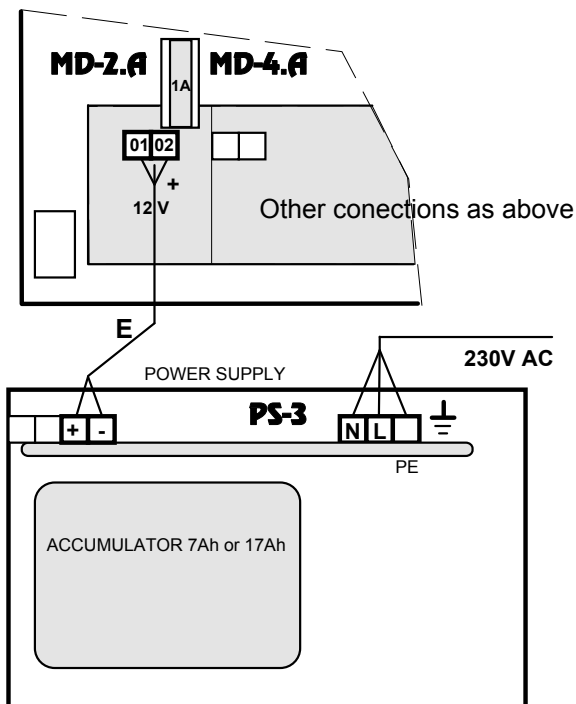
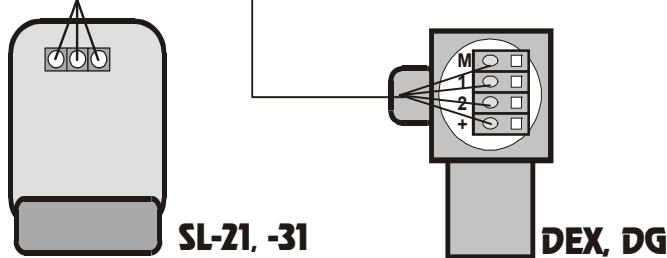

12V DC power supply connection

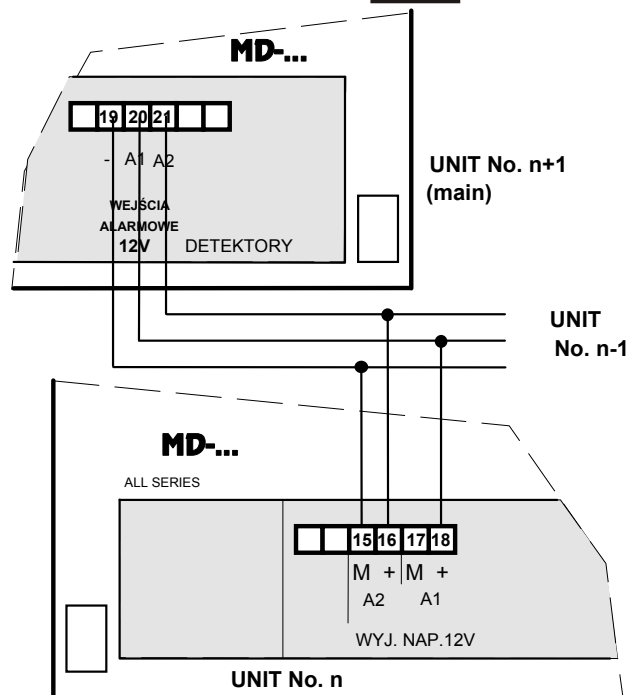

Cascade connection of units

Table 3.1. Functions performed at the outputs:

State of the UNIT	RELAY Outputs "WYJŚCIA STYKOWE"						12VDC Outputs „WYJŚCIA NAP.12V”	
	"AWARIA"		A1		A2		A1	A2
	pins COM-NO [11] [12]	pins COM- NC [11] [13]	pins COM-NO [06] [07]	pins COM- NC [06] [08]	pins COM-NO [03] [04]	pins COM- NC [03] [05]	[17] [18]	[15] [16]
NORMAL	open	CLOSED	open	CLOSED	open	CLOSED	0V	0V
A1	open	CLOSED	CLOSED	open	open	CLOSED	12VDC	0V
A2	open	CLOSED	CLOSED	open	CLOSED	open	12VDC	12VDC
FAULT "AWARIA" MD power failure	CLOSED	open	open	CLOSED	open	CLOSED	0V	0V
FAULT "AWARIA" Detectors power failure	CLOSED	open	CLOSED	open	CLOSED	open	12VDC	12VDC
SERVICE	open	CLOSED	open	CLOSED	open	CLOSED	0V	0V

Description of MD states:

NORMAL state gas concentration in all connected detectors below A1 and thresholds, only green lamps of [ZASILANIE] (POWER) and [ZASILANIE MODUŁU] (MODULE POWER) of activated detectors are on

A1 – (ALARM 1) at least one detector indicates the A1 concentration threshold has been exceeded but no detector indicates the exceeding of A2 threshold;

„ON” lamps: [ALARM1] – at least one Input State and [ALARM1] lamp of Output State (external alarm)

„ON” lamps: [ZASILANIE MODUŁU] (MODULE POWER) and [ZASILANIE] (POWER) of active detectors.

A2 – (ALARM 2) at least one detector indicates the A2 concentration threshold has been exceeded, red [ALARM1] and [ALARM2] Input State lamps of at least one detector are on and [ALARM1] and [ALARM2] Output State lamps are on or

only [ALARM1] and [ALARM2] Output State lamps are on (external alarm);

green [ZASILANIE MODUŁU] (MODULE POWER) and [ZASILANIE] (POWER) lamps of active detectors are on

FAULT "AWARIA" (MD power failure)– no power or main fuse burnt – all lamps are out

FAULT "AWARIA" (Detector power failure)– at least one detector with blinking [ZASILANIE] (POWER) lamp and [ALARM1] and [ALARM2] Input State lamps on, [ALARM1] and [ALARM2] Output State lamps on (delayed activation); [ZASILANIE MODUŁU] (MODULE POWER) and [ZASILANIE] (POWER) lamp of the remaining activated (operational) detectors is on; yellow [AWARIA SYSTEMU] (SYSTEM FAILURE) lamp is on

SERVICE –W2 „SERWIS” switch set to „ON” – all outputs disabled (as in Normal state) irrespective of the states of inputs; yellow [AWARIA SYSTEMU] (SYSTEM FAILURE) lamp is on, remaining lamps according to one of the above mentioned states

Other combinations of output states are regarded as failures.

Table 3.2. Functions performed using function switches

Switch	Symbol	Description of action	„OFF” position (lower)	„ON” position (upper)
W1	1	Detector No. 1 power control	detection line #1 is off	Detector No.1 power is on
W1	2	Detector No. 2 power control	detection line #2 is off	Detector No.2 power is on
W1 (only MD-4...)	3	Detector No. 3 power control	detection line #3 is off	Detector No.3 power is on
W1 (only MD-4...)	4	Detector No. 4 power control	detection line #4 is off	Detector No.4 power is on
W2	SERWIS (SERVICE)	shutting off alarm contact and 12V outputs	outputs active, normal operation	outputs interlocked
W2	CISZA (SILENCE)	internal siren control	siren active, normal operation	siren off
W2	BEZ PAM. (NO MEMORY)	optical memory of alarm states at outputs and inputs	active memory	memory off

Table 3.3. Meaning of optical indication of the module

STATE/ MD status	DESCRIPTION of the state	Lamp	Lamp	OUTPUT STATE lamps		INPUT STATE lamps (N detector)		
		yellow	green	red	red	green	red	red
		SYSTEM FAILURE	MODULE POWER	ALARM 1	ALARM 2	POWER	ALARM 1	ALARM 2
Normal	MD power on, no activated detectors	0	1	0	0	0	0	0
Normal/heating	period of preliminary stabilization of detectors operation	0	1/0	0	0	x	0	0
NORMAL	system operation	0	1	0	0	1	0	0
Normal / A1	preliminary stage of N detector operation with exceeded A1 threshold	0	1	0	0	1	1	0
Normal/ A1 mem. at the input (*)	temporary exceeding of A1 threshold of N detector (e.g. detector test)	0	1	0	0	1	1/0	0
Normal / A2	preliminary stage of N detector operation with exceeded A2 threshold	0	1	0	0	1	1	1
Normal / A2 mem. at the input (*)	temporary exceeding of A2 threshold of N detector (e.g. detector test)	0	1	0	0	1	1/0	1/0
ALARM 1	A1 alarm of N detector	0	1	1	0	1	1	0
Normal/ A1 mem. at the output (*)	stored A1 state of N detector at the outputs	0	1	1/0	0	1	1/0	0
ALARM 1	external A1 alarm in progress	0	1	1	0	x	x	x
Normal/ external A1 memory (*)	stored external A1 alarm	0	1	1/0	0	x	x	x
ALARM 2	A2 alarm of N detector in progress	0	1	1	1	1	1	1
Normal/ A2 mem. at the output (*)	stored A2 state of N detector at the outputs	0	1	1/0	1/0	1	1/0	1/0
ALARM 2	external A2 alarm	0	1	1	1	x	x	x
Normal/ external A2 memory (*)	stored external A2	0	1	1/0	1/0	x	x	x
Failure	no power supply to MD	0	0	0	0	0	0	0
Failure	power supply to N detector	1	1	x	x	1/0	1	1
SERWIS (SERVICE)	disabling of outputs (W2 „SERWIS” in ON position)	1	1	x	x	x	x	x

(*) – with W2 „BEZ.PAM.” (NO MEMORY) configuration switch set to „OFF”; set to ON = as in Normal state

Meaning of lamp statuses:

0 = off,

1 = on ,

1/0 = slowly blinking,

x = any state (resulting from system configuration or previous states).

4. INSTALLATION OF MD IN THE SYSTEM



4.1. Install the module in the appropriate place, inaccessible for unauthorized persons, out of explosion-hazardous area, free from strong electromagnetic interference, vibrations and impacts.

4.1.1. Remove terminal compartment cover to gain access to the two mounting holes.

4.1.2. Hang the module on a previously prepared single hook (in the centre of the designated mounting area); mark points for the two remaining mounting holes (mounting position according to Fig. 3). Drilling template = lid of MD cardboard box.

4.1.3. Insert anchor bolts; fasten the module with bolts. Fixing must be secure, firm and without play.

4.2. Insert „A” connecting cables from **DEX** detectors (of circular cross-section) through the cable glands.

Select cross-sectional area (‘‘A’’) of cable conductors depending on the length (‘‘L’’) of the connection

L	L < 150m	L < 300m	L < 450m
A:	0.5 mm²	1 mm²	1.5 mm²

4.2.1 Maintain proper order of cables connecting with the detectors; wrong order will cause alarm state or malfunctioning of the system.

4.2.2.A. Inserting the conductor to self-clamping terminal (straight or oblique):

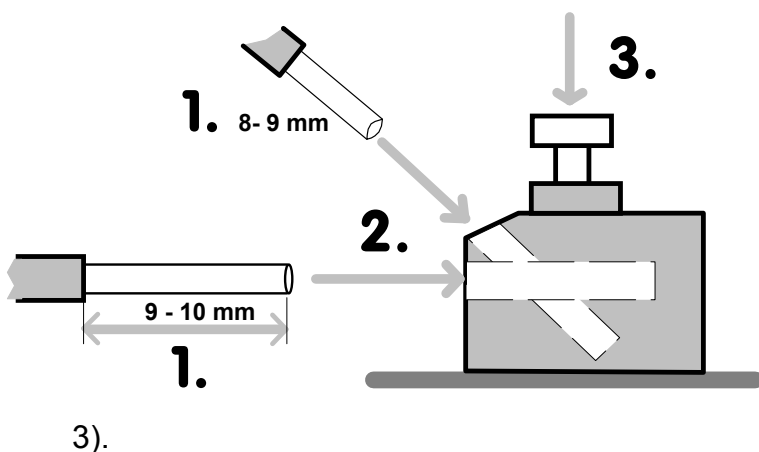

1. Remove conductor insulation from exactly 9 to 10 mm (straight) or 8 to 9 mm (oblique) cable section.

2. Using pliers push (insert) the non-insulated end of the conductor into the round opening of the terminal as far as it goes.

If properly inserted the cable cannot be pulled out of the terminal.

The cable can be released and taken out only after prior pushing the lever (3) (white or grey, according to the arrow

4.2.2.B. Introduction of conductor into spring-loaded terminal of **cage** type:

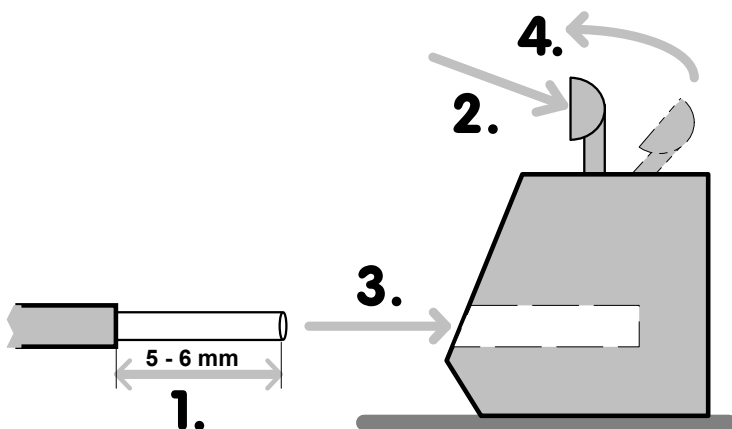

1. Remove insulation from (exactly !) 5 to 6 mm long section.

2. Push the spoon-shaped terminal lever with a thin screwdriver.

3. Introduce cable conductor into the exposed terminal opening.

4. Release the lever.

If properly inserted the conductor cannot be pulled out of the terminal.

The conductor can be released and taken out only after pushing the lever.

4.2.3. Prepare the ends of the cables so that, when inserted into the terminal compartment, the conductors need not to be looped inside the module and the gland seal is tight around the outer cable insulation. It is recommended to use wire cables. Stranded cables can only be used after prior inserting the cable ends into clamp sleeves.



Clamping of the cable in the gland should be firm enough not to allow the cable to be removed from the MD if pulled manually. Additionally it must not transfer mechanical forces to terminal clamps. This will ensure proper sealing.

4.2.4. The module is supplied with detector No. 1 circuit activated. Where more DEX detectors are to be installed activate power supply circuits with W1 microswitches „WYŁĄCZ” („DEACTIVATE”) on the terminal board (with number corresponding to the number of the detector

to be activated), by sliding it to "ON" position ([ZASILANIE] (POWER) lamp of the corresponding detector is lit)

4.4. Connect external associated devices e.g. automation system control, external S-3 siren, LD-2 warning lamp (YTKSY 2 x 0.5) etc. Where optical and sound signalling devices are to be located in the same place it is recommended to use an integrated sound and optical signalling device type SL-31 or SL-21. With siren and lamp functions separated they can be connected to MD with C3 3-conductor cable (recommended type: 2 x 2 x 0.5) Mains power of different phases or low-voltage circuits can be connected to A1 and A2 contact outputs. Only low-voltage circuits can be connected to AWARIA (FAULT) contact output.

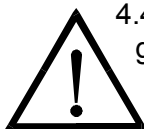

4.4.1. Where it is necessary to connect more cables (after all factory-provided module cable glands are used) additional glands (of diameters appropriate for the cables to be used) should be installed on the removable terminal compartment cover. Use appropriate glands (IP54 or better) to ensure the module tightness class is kept. It is forbidden to make holes in walls or bottom of the module! It is not allowed to insert cables into MD directly through the openings drilled (without cable glands) or through the seal of the terminal compartment cover.



4.5. For MD-2(4) connect 230V AC power supply „B” cable. The module is equipped with internal, 1-pole power switch. MD requires no earthing and has no protection terminal. However, the sequence of conductors of the 230V joint must be observed: phase conductor to „L” terminal [02], neutral conductor to „N” [01]. Reliability and lack of interference is the basic requirement for effective system operation and therefore „B” conductor must be connected via the separated fuse on the switchboard. High overvoltage in 230V AC power supply circuit can damage the internal main power fuse or cause interference in the operation of MD.

For MD-...A: connect 12V DC power supply „E” cable from the PS... power pack (with battery connected); observe polarity (module is secured against reverse polarity).

Cross-sectional area of „E” cable conductors	Length of „E” cable
1.5 mm ²	≤ 12m
2.5 mm ²	≤ 20m

4.5.1. Turn on module power supply. Presence of power and proper powering of circuits are indicated by lighting of green lamps and [ZASILANIE] (POWER) of the active detectors and the blinking green [ZASILANIE MODUŁU] (MODULE POWER) lamp (blinking approx. 1 minute during heating). Completion of heating period is indicated by continuously lit [ZASILANIE MODUŁU] (MODULE POWER) lamp. Blinking [ZASILANIE] (POWER) lamp of the detector indicates overload of „+” output supplying power to that detector.

4.5.2. **CAUTION:** In case of inadvertent, instantaneous shorting of detector power supply cables or overloading of the power line or wrong polarity of „A” cable during installation power supply of that detector will be automatically cut off by electronic fuse. This will cause the green [ZASILANIE] (POWER) lamp to start blinking, A2 alarm state to be activated and the internal siren to produce intermittent signal. Once the short-circuit or the overload are removed the internal fuse will restore power supply only after the module power supply is turned off for approx. 5 seconds and turned back on afterwards.

4.5.3. Overload or short-circuit in one of the voltage outputs [WYJŚCIA NAP.12V] (12V OUTPUTS) occurred during A1 or A2 state will cause the self-resetting fuse to be triggered. Once the short-circuit or the overload are removed the internal fuse will restore normal operation after a period not longer than several seconds.

4.6. The heating (output locking) period is approx. 1 minute long. After that period the detectors resume normal operation and none of the alarm lamps should be lit or blinking. The module goes to NORMAL operation state. This proves the **System** components have been properly installed.

4.7. The final stage of inspecting the **System** operation is generation of all alarm states for all detectors connected.

4.8. ASSUMING THAT:

- **MD** unit is normal state (after the sensor heating period is over), [**ZASILANIE**] (**POWER**) lamps of detectors and [**ZASILANIE MODUŁU**] (**MODULE POWER**) are lit,
- **DEX** detectors do not produce any alarm signals (gas concentration below calibration thresholds),

4.8.1. Activate alarm state of each detector (one by one) using test gas, according to the recommendations provided in the detector operating manual. At that point (or after a delay of several seconds) [ALARM2] and/or [ALARM1] Input State control lamp should light up corresponding to the detector being tested and intermittent sound of internal siren should be heard. The internal siren can be muted by sliding W2 function selector "CISZA" (MUTE) to "ON" position.

4.8.2 Should A1 or A2 alarm signal of DEX detector last longer than 20 seconds alarm signal will be activated on control A1 and A2 outputs and corresponding red control lamp of Output State will light up.

4.8.4. Upon removal of test gas the gas concentration in the detector chamber is gradually reduced, Output and Input States [**ALARM2**] lamps, followed by [**ALARM1**] lamps, start to blink (instead of being permanently lit). When all the lamps are blinking reset the alarm state memory by pressing [**KASOWANIE PAMIĘCI**] (**MEMORY RESETTING**). All [**ALARM1**] and [**ALARM2**] lamps should go out and the module should go to Normal state. Alarm memory can be turned off by setting W2 „BEZ.PAM.” (**NO MEMORY**) function switch to „ON” position. Fading of alarm signal will automatically cause the corresponding control lamps to go out.

4.8.5. Procedure of control of outputs can be simplified by pressing [**TEST**] button on the module terminal board and holding it pressed for a couple of seconds. Immediately after the button is pressed only two Output State control lamps should light up and corresponding control signals should be present on both outputs. Upon releasing the button both Output State lamps will start blinking (alarm state memory) and the output signals will fade. Temporary pressing of [**KASOWANIE PAMIĘCI**] (**MEMORY RESETTING**) button on the module front plate will cause both lamps to go out and the unit to go to normal operation mode.

4.8.6. During subsequent testing procedures, if so required by the system user, it is possible to interlock the operation of alarm outputs by switching W2 „SERWIS” (**SERVICE**) switch to “ON” position. Once the detectors operation test is completed set the switch to normal „OFF” position – the lower position, closer to the terminal strip.

Record the inspection or start-up results in the attached Periodical Inspection Protocol.

If the test is passed successfully the **Two-Threshold Gas Detection System** can be considered as started up and operational.



4.8.6. Attach the unit terminal compartment cover;

- tighten cable glands (firmly enough not to transfer mechanical loads if an attempt is made to pull the cable out manually).

- seal unused cable glands (using the factory-supplied red plugs or e.g. by tightening short pieces of cables inside).

- tightly close the transparent unit cover.

- It is recommended to put a seal on the unit covers (to limit the access to the MD by unauthorized persons).

PROBLEM ?

Before you call MD manufacturer check and compare the effects with those described below

4.9. TABLE of exceptional unit state after turning the power on:

EFFECT	WHY	WHAT TO DO
[Zasilanie] (<i>Power</i>) lamps are on, [Zasilanie modułu] (<i>Module power</i>) lamp is blinking, no siren	detectors heating period in progress (alarm outputs are interlocked)	wait approx. 1 min.
Input State [ALARM2] and/or [ALARM1] lamps are permanently lit for several/several tens of seconds and start blinking afterwards	if DEX has been stored for a long time or at low ambient temperature; heating period was longer than the assumed 1 min. time (applies to detectors with low calibration levels)	temporary pressing [KASOWANIE PAMIĘCI] (<i>MEMORY RESETTING</i>) button while the lamps are blinking (and none of them is permanently lit) should bring the unit back to normal state
Input State [ALARM1] or [ALARM2] lamps of a specific detector are permanently lit all the time	wrong power polarity or damaged „A” connecting cable or wrong sequence of signal conductors	change polarity and sequence of conductors to the proper one or replace „A” connecting cable
Output State [ALARM1] and [ALARM2] lamps and/or Input State [ALARM1] or [ALARM2] lamps of a specific detector are permanently lit, intermittent sound emitted by the internal siren, green [ZASILANIE] (<i>POWER</i>) lamp of the specific detector is blinking, green [AWARIA SYSTEMU] (<i>SYSTEM FAILURE</i>) lamp is on	overload above 200mA or shorting of power circuit of the specific detector	remove the cause of the short circuit or the line overload; turn the power off for 5 seconds
signalling device(s) connected to „NAP.12V” (<i>12V VOLTAGE</i>) outputs is/are not operating in A2 or A1 states	short circuit in connecting cable or damaged signalling device; self-resetting fuses have tripped	Turn MD power off. Remove the short circuit in the cable or repair the signalling device. Turn the power on; Check the signalling devices using „TEST” button.
power lamps: on; Output State [ALARM2] and/or [ALARM1] lamps: on; Input State lamps: off; internal siren emitting intermittent sound; alarm indication system: on	voltage connected to 12V Alarm Inputs on A2 and/or A1 terminals (cascade connection)	ALARM signal from external devices, (mother detectors in normal state), Alarm Inputs work without delay!
all lamps are out	no power or main power fuse burnt	turn the power on or replace the fuse (with identical, slow blow fuse), carry out the replacement with power shut off

When effects other than those described above are observed contact the Authorized Distributor or Manufacturer.

5. MAINTENANCE / OPERATION

MD units are electronic devices with no moving mechanical parts. They are built with the use of semiconductor components of many years of service life. Therefore, the maintenance is limited to Periodical System Inspection.

5.1. Periodical System Inspection:

- ◆ Remove dust from MD covers
- ◆ Check tightness of the transparent cover and cable glands,
- ◆ Notify all System users of the scheduled inspection
- ◆ **Test the System according to Section 4.8.** of this manual.

*Recommended interval of periodical inspection of MD being at least **every 3 months** is sufficient for testing the electrical and measuring properties of the System*

- ◆ The Periodical System Inspection must also be performed after EACH occurrence of exceptional conditions in system operation i.e.:
 - occurrence of temporary extreme conditions e.g. high gas concentration, high or very low temperature, temporary high dust concentration or increased humidity,
 - high concentration of other gases the presence of which was not anticipated in the monitoring area,
 - long time operation with alarm state on,
 - interruption in power supply longer than approx. 6 hours,
 - overvoltage or strong interference in electrical system,
 - overhaul or installation work which may affect the functioning of the system or the system configuration etc.



5.2. During operation do not use mobile phones, radiophones or other sources of strong electromagnetic field in direct vicinity of MD as their use may cause interference in operation of MD or false alarm states.

CAUTION! IMPORTANT!!

5.3. All:

- results of each system inspection performed according to 4.8. of this manual,
- events when A2 state was activated, including actions taken by the personnel,
- events of shutting the unit off for a period longer than 3 months,
- noticed abnormal symptoms of system operation

MUST be entered in the attached Periodical System Protocol or the **warranty** for the system components **shall be null and void.**

NOTE:

In view of the continuous product improvement process and the efforts to provide as full and detailed information on those products as possible and to transfer knowledge necessary for proper, long-time operation of the products on the basis of the previous experience of the Customers, GAZEX reserves the right to introduce minor changes in specifications of the products supplied and not indicated in this Manual and to change the content of this Manual. Therefore, you are requested to verify and confirm with the Manufacturer that the version of the User's Manual in your possession is up-to-date (provide type and series of the device used and the number of the manual issue indicated in the document's footer).

PERIODICAL INSPECTION PROTOCOL

OF THE ACTIVE SAFETY SYSTEM OF THE GAS SYSTEM[®] or
 TWO-THRESHOLD GAS DETECTION SYSTEM or
 DETECTORS AND MEASURING INSTRUMENTS manufactured by **gazex[®]**

Serial numbers of the devices in the System
 (fill in the table before System installation!)

<i>DEVICE</i> (type)	<i>VERSION</i> (calibration)	<i>SERIAL NUMBER</i>	<i>REMARKS</i> (location)

The protocol includes five numbered sheets with gazex logo on the reverse side.

DETECTOR / SYSTEM START-UP:

DATE of the start-up	Time	<i>Remarks</i> on the system components	Remarks on place or method of installation	Actions taken	Started up by (full name)	Signature
01						
02						

Inspection DATE	Time	DETECTOR No. / state	RESPONSE	OTHER symptoms (valve condition)	Actions taken	Legible signature of the inspector (full name)
1						
2						
3						
4						
5						
6						
7						
8						

gazel

PERIODICAL INSPECTION PROTOCOL